

The Glitch & The Fix – March 2009

© Copyright 2009, J. Siegenthaler, all rights reserved

Been There, Done That

The Glitch

Overview: Many years ago (when I knew enough about hydronics to be dangerous) I put together a system to provide radiant floor heating and domestic water heating for a building addition.

The original building was heated by a well-oversized steam boiler. That boiler had two “bays” for tankless coil water heaters. Not wanting to intermingle the water in the old steam boiler with that in the new system, I installed a very compact tankless coil in the steam boiler, and used it as an isolated heat source for the new system as shown. With the boiler maintaining a minimum temperature of 160 degrees F, and climbing to around 215 degrees F during the steam cycle, this coil had plenty of capacity to handle the new load.

The floor heating portion of the system worked well. It used a high head circulator to provide flow through several thousand feet of PEX tubing. The system also did a good job of heating domestic water. However, if floor heating and domestic water heating occurred at the same time, I discovered there was no flow through the heat exchanger in the indirect tank.

I assumed the small circulator supplying the indirect heater was defective, so I opened it up for a look and test. It was clean and operated fine. After putting it back in the system the problem persisted.

Exercise: So, with the small circulator running, why was there no flow through the heat exchanger in the water heater? Can you figure out what was happening? Also, can you spot some other details in the schematic that should be changed?

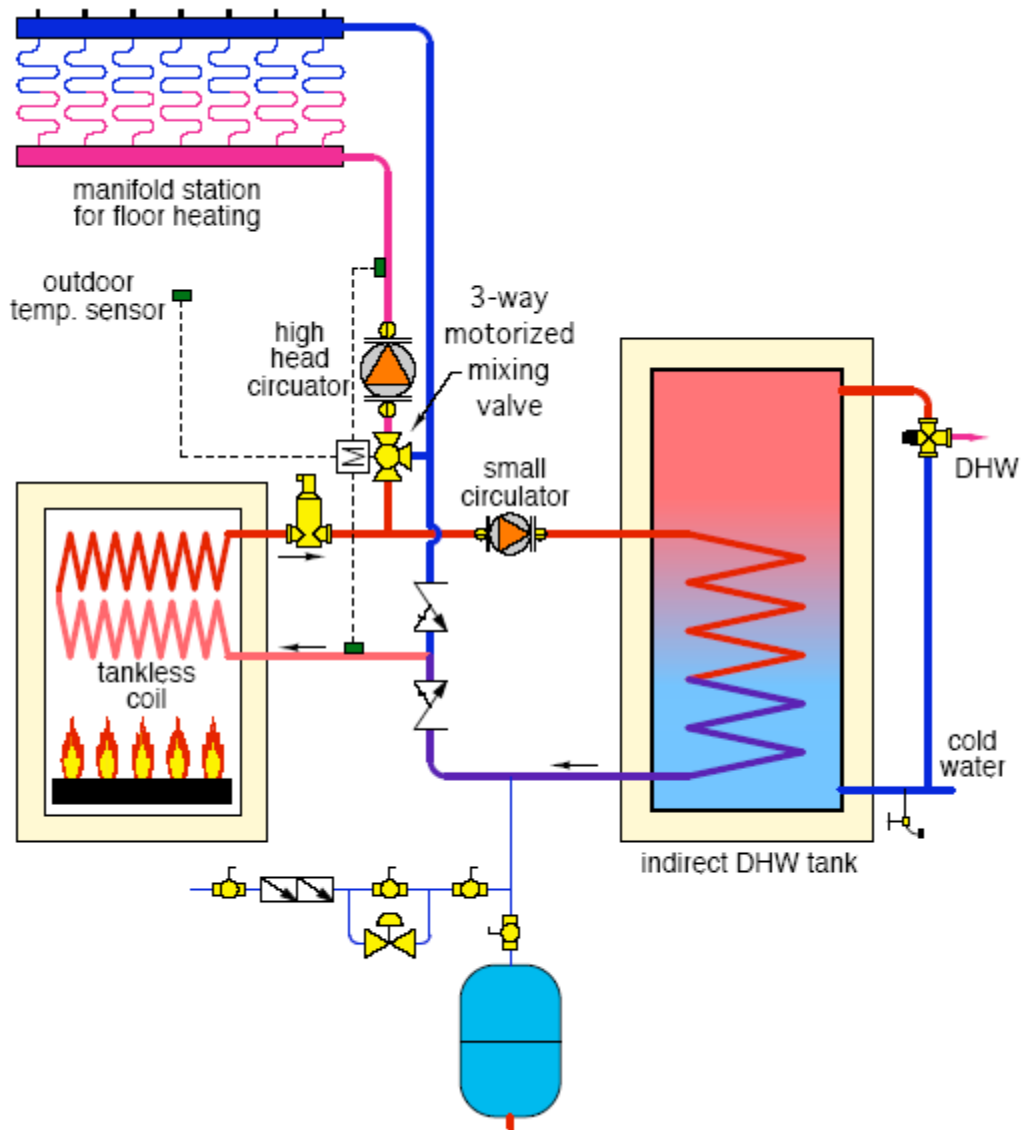

The Fix

This one took some head scratching. What we eventually found was that the pressure differential created by the high head circulator supplying the radiant portion of the system — in combination with the high flow resistance through the compact tankless coil — was creating a situation where the pressure in the return header was several psi higher than that in the supply header. This pressure differential was present whenever the high head circulator operated. It was also greater than the “shut off” differential pressure of the smaller circulator (e.g. the maximum pressure differential the small circulator can create). This backseated the check valve in the indirect circuit, and “deadheaded” the small circulator.

Pressures representing the situation with both circulators running are shown in the first fix drawing. Notice that the pressure on the discharge side of the small circulator

is 10 psi. This is 5 psi higher than at its inlet, and it's the maximum pressure differential it can muster. At the same time the high flow resistance of the tankless coil causes the pressure in the return header to be 12 psi. Hence the lower flow check is backseated and there is no flow through the heat exchanger in the water heater.

We corrected the situation by rewiring the indirect water heater to operate as a priority load (i.e., the easier fix). However, using a hydraulic separator as shown in the fix drawing could have eliminated this interference. A separate circulator would provide flow through the boiler. The pressure differential created by this circulator would be isolated from the two distribution circulators. The latter would also be isolated from each other by the hydraulic separator in combination with the "short and fat" headers.

The moral of the story: When big circulators and small circulators can "see" each other (e.g., each can sense the pressure differential created by the other) they will "fight". If the heat source and common piping produce high flow resistance, the fight will be intense, and the big circulator will win every time. Stop the fights – provide hydraulic separation of circuits.

Other changes in the fix drawing include:

- Adding purging valves on the return side of each load circuit
- Moving the expansion tank connection point near the bottom of the hydraulic separator
- Eliminate the original "bullhead tees" between the flow checks
- Putting the flow check valves on the supply side of each load circuit to help minimize heat migration

WHAT HAPPENS WHEN BOTH CIRCULATORS OPERATE

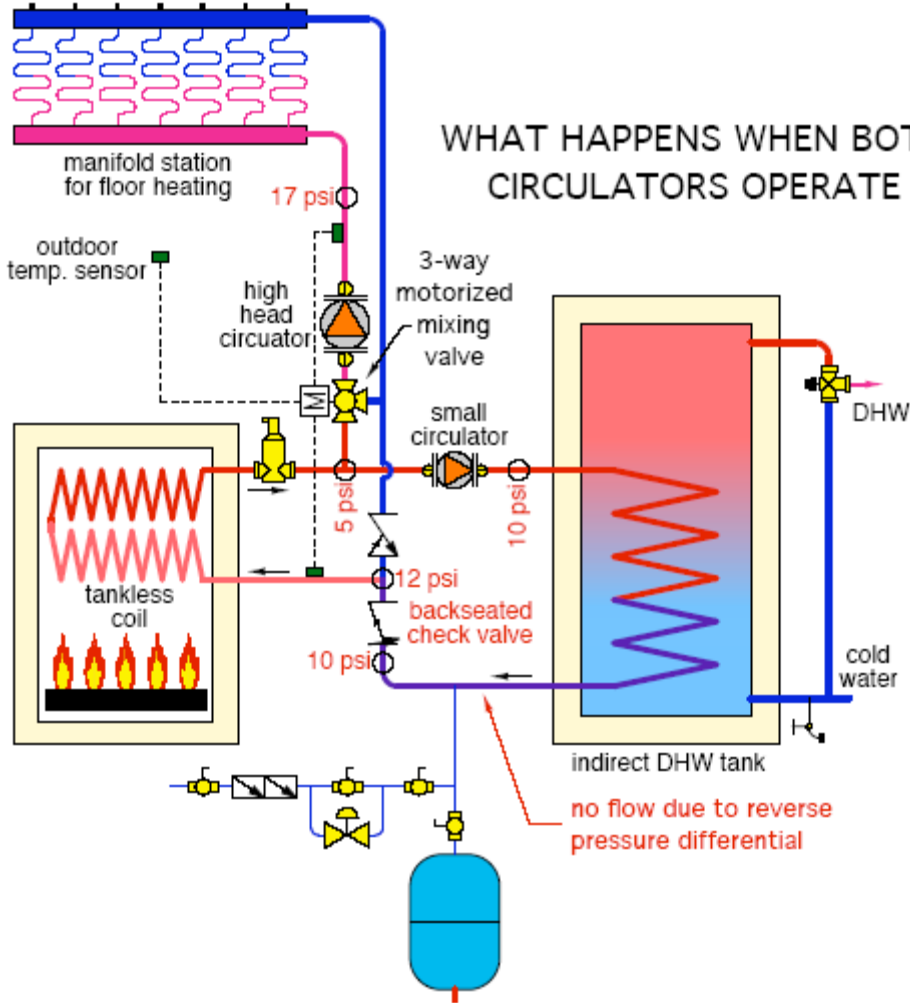

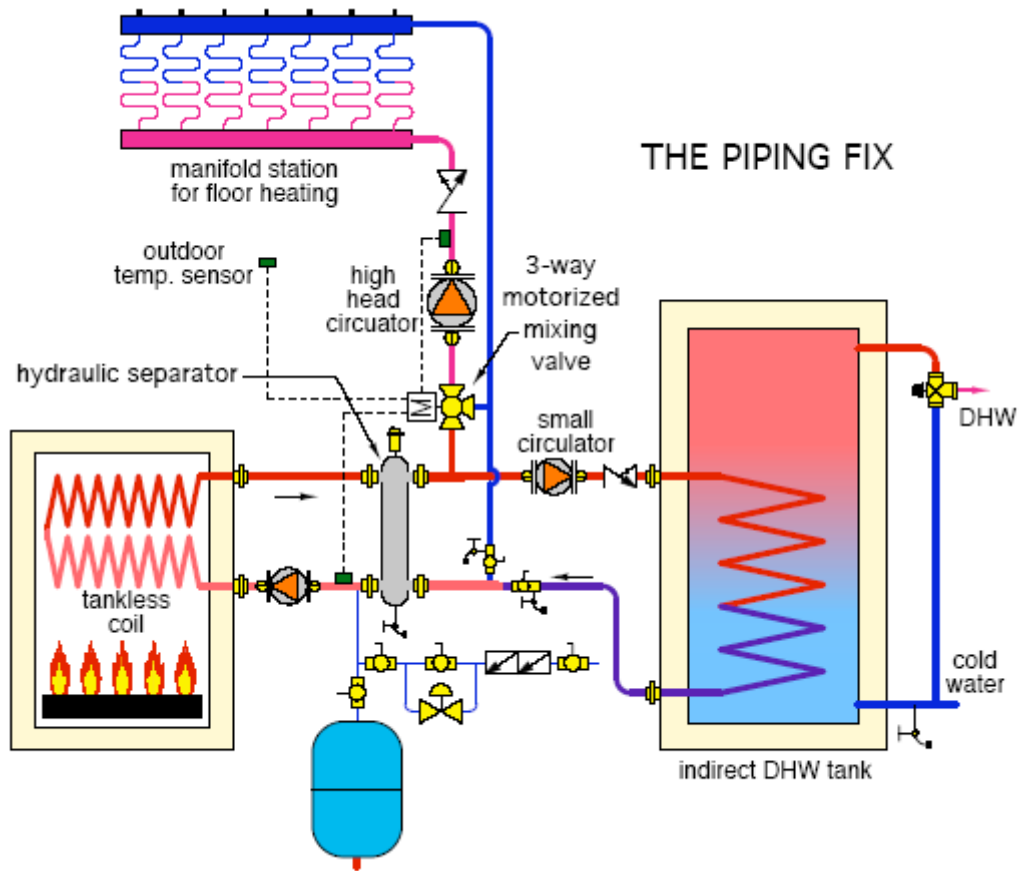

Visit www.HydronicPros.com