

Trying Something New

The Glitch

Overview: A heating contractor, who's tired of coaxing 500-pound cast-iron boilers into homes, decides to try out a wall-mounted mod/con boiler because of its light weight and side wall venting.

He pipes it up as shown below. All flow to the distribution system supplying several radiant panel manifolds passes through the three-way thermostatic mixing valve. When purchasing the boiler, the installer was told to use a pair of closely spaced tees to separate the boiler and distribution system, so he installed some closely spaced tees as shown.

Exercise: Can you spot at least four things that should be changed in this layout?

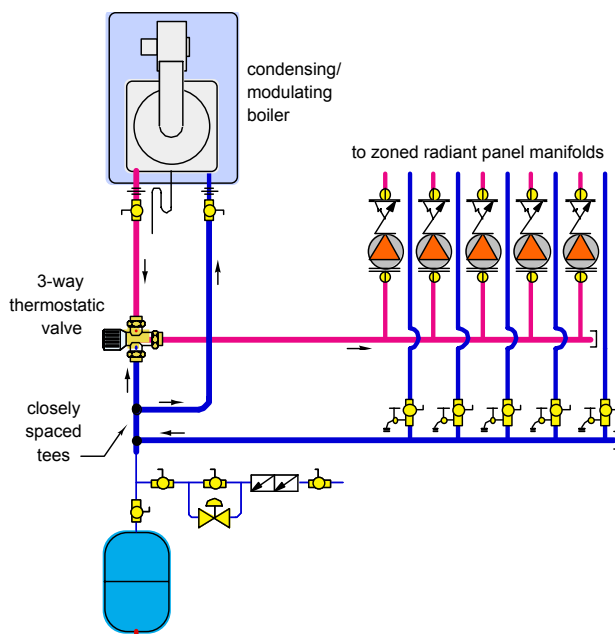

The Fix

Well, those are closely spaced tees under the boiler, but they don't serve to hydraulically separate the boiler from the distribution system.

Another poor choice is to install a 3-way thermostatic mixing valve (or any mixing assembly for that matter) between a mod/con boiler and the distribution system. It

makes no sense to operate the boiler at a temperature higher than needed by the distribution system, and then mix down the water temperature. This reduces the ability of the mod/con boiler to operate with flue gas condensation and thus reduces efficiency. Furthermore, if that 3-way thermostatic valve has a low Cv — which is typical of valves of 1-inch pipe size or less — it's going to act as a significant flow restrictor to the distribution system. Low flow leads to wide delta T on the radiant panel circuits and very likely to insufficient heat delivery.

It's also likely that reduced flow through the mod/con boiler will lead to operating problems, especially in boilers with low mass heat exchangers.

A good microbubble air separator also needs to be added to the system. For the best performance install it where the fluid is hottest, near the boiler outlet.

Finally, take a look at how the circuit purging valves are installed on the zone returns. In this orientation the only thing they will be purging is the return manifold.

The corrections are shown below.

