

What's Wrong?

The Glitch

Overview: A low-temperature (concrete slab) radiant floor panel is being supplied by a conventional gas-fired cast-iron boiler. Supply water temperature is controlled by a motorized three-way mixing valve. The system includes a boiler bypass circulator to prevent thermal shock to the boiler.

Exercise: So what's wrong with this arrangement?

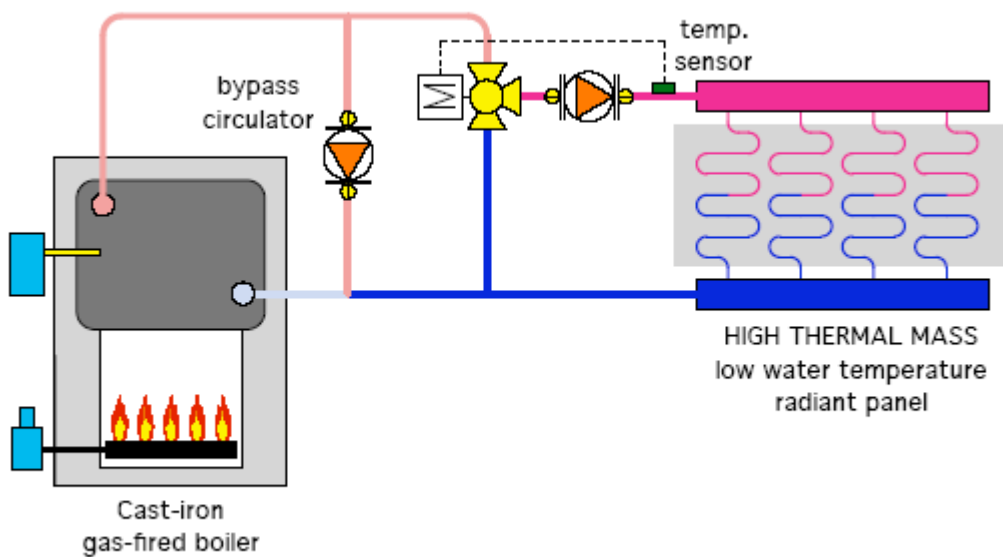

The Fix

A bypass circulator does help protect a cast-iron boiler from thermal shock by blending water from the boiler's outlet into a potentially cold return stream. However, it does not protect the boiler from sustained flue gas condensation. Only a device that monitors boiler inlet temperature and reacts by decreasing the rate of hot water entry to the mixing device can do this.

The fix is to use a mixing valve controller that monitors boiler inlet temperature. It's also a good idea to isolate the pressure dynamics of the boiler loop from those of the distribution loop. This is easily accomplished with a pair of closely spaced tees.

